

SOLOHEAT LTD - TUBULAR / IMMERSION HEATER SPEC SHEET

TEL: +44 (0) 1453 752459 | E: SALES@SOLOHEAT.CO.UK

CUSTOMER: _____

NAME: _____

CONTACT: _____

DIE REF #/NAME: _____

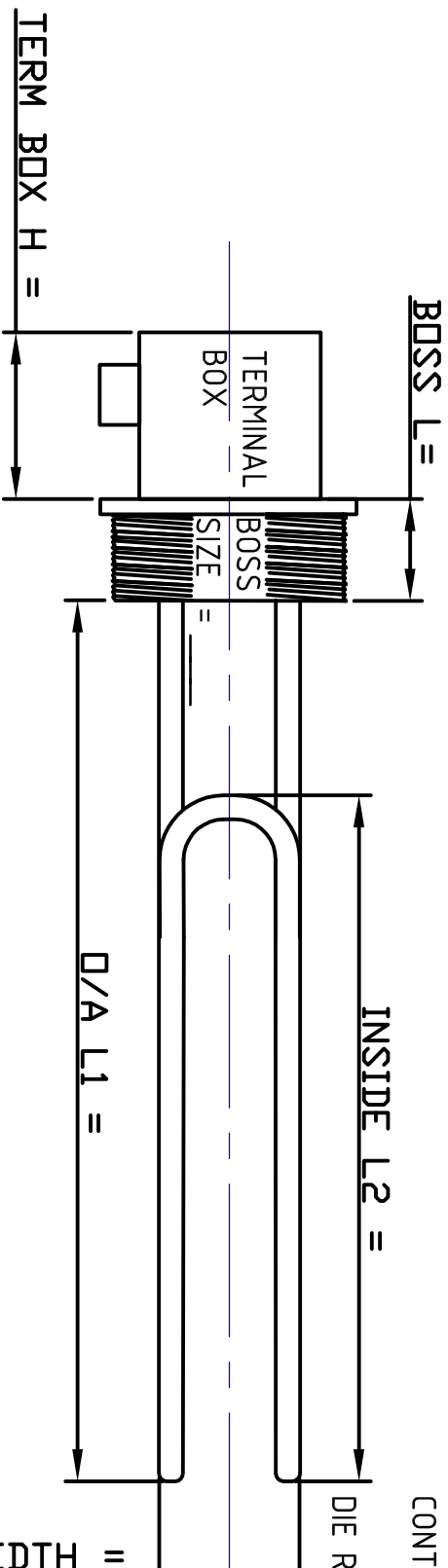

O/A WIDTH = _____

ADDITIONAL INFO:

TUBE DIA: _____ TUBE LENGTH (IF UNFORMED): _____ INTERNAL COLD END LENGTH EACH END: _____

IMMERSION DIMS : O/A L1 _____ X INSIDE L2 _____ X O/A WIDTH _____ BOSS SIZE _____

VOLTAGE _____ WATTAGE _____ 3PHS -STAR | DELTA | 2PHS | 1 PHS

TERMINATION: THREADED TERMINAL PINS | TERMINAL BOX | HARDWIRE LEADS

LEAD DETAIL: LENGTH _____ PLAIN FIBRE GLASS | STEEL BRAIDED | SILICONE | STEEL CONDUIT

